

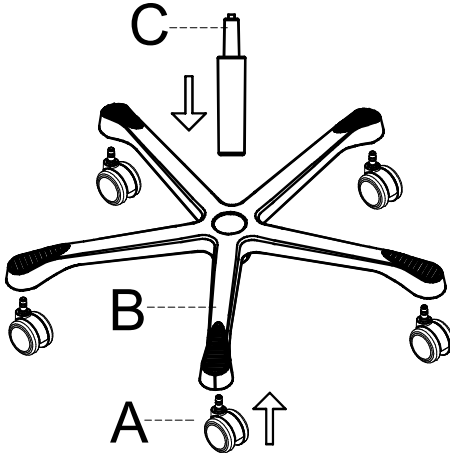

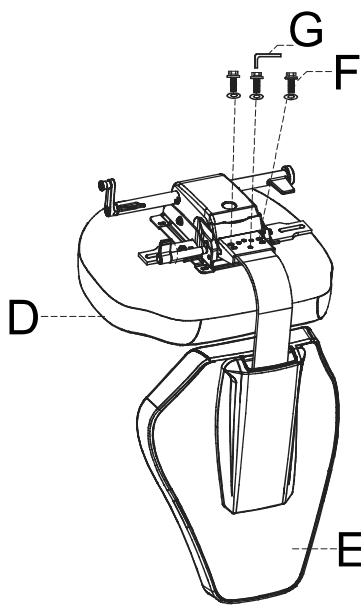

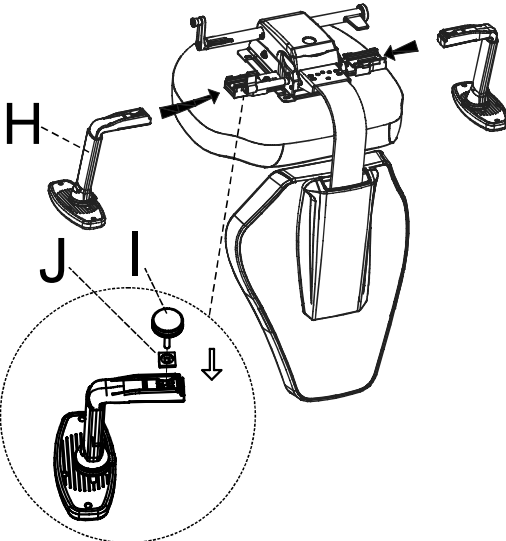

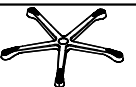

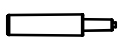

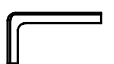
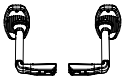

Part	Picture	Qty.	1	2	3
A		5			
B		1			
C		1			
D		1			
E		1			
F	 M8x20	3			
G		1			
H		2			
I		2			
J		2			
K		1			
L	 M6x25	2			
M		1			
N		1			

Headrest adjustment:

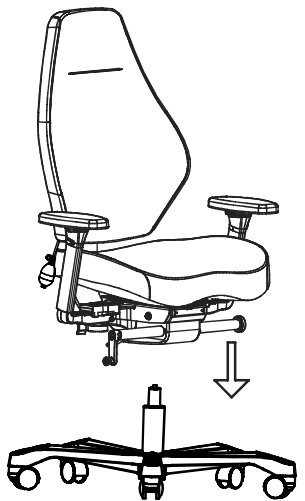
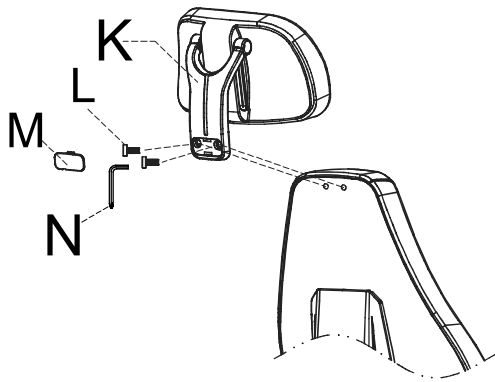
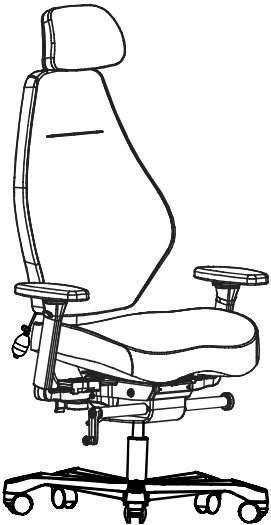
To rise: Hold the headrest (①) with both hands and lift it up to a suitable height.

To lower: Hold the headrest with both hands and pull it down to a suitable height.

To adjust the headrest angle: Hold the headrest with both hands and turn it to a suitable angle.

Back height adjustment :

To rise: Hold the bottom of the chair back(②) with both hands and lift it up to a suitable height step by step.

To lower: Hold the bottom of the chair back with both hands and lift it step by step. After crossing the highest position, the back can be lowered to the lowest position.

Attention: Backrest can NOT lower down during the adjustment to upward; Only can lower down to lowest position when reaching the highest position and release your hands.

Armrest adjustment (③):

To rise or lower: Press the button while holding the armrest, lift it up or lower it down, release when reaching a desired height.

Armpad angle to left or right: Grasp the armpad and press the button under the armpad, pivot to left or right. Armpad can rotate 360 degree.

Armpad forward and backward: Grasp the armpad, slide forward or backward.

Armrest width: Turn anticlockwise the knob to unlock, grasp the armrest to pull out or push in, turn clockwise the knob to lock when reaching proper position.

Seat angle adjustment (Forward Tilt):

To adjust the seat angle: Turn clockwise the handle (④), the rear part of the seat will be lifted up, while reaching the stop point, the seat angle can be locked.

To return: Turn anticlockwise the handle, the rear part of the seat will lower down automatically.

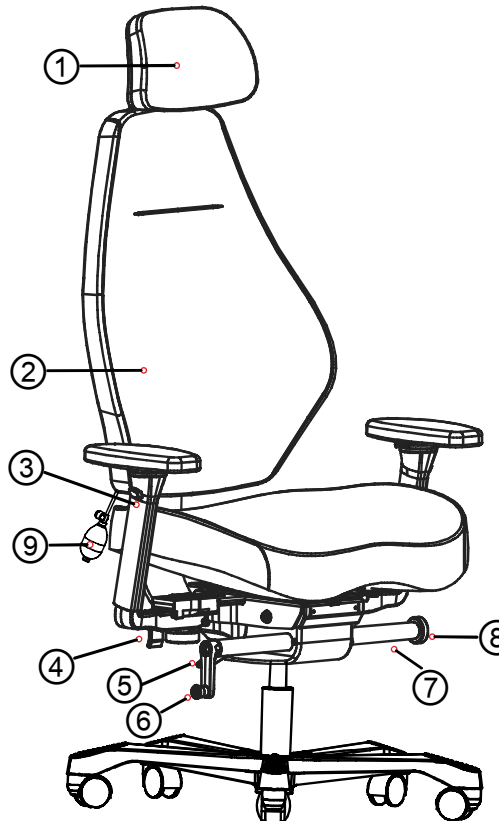

Seat height adjustment:

To raise: Lift up the lever (⑤) when leaving or half up, release the lever when reaching a desired height.

To lower: While sitted, lift the lever up, release the lever when reaching a desired height.

Tilt tension adjustment:

To increase: Turn clockwise the handle (⑥) to stronger.

To reduce: Turn anticlockwise the handle to weaker.

Seat depth adjustment:

To increase: While sitted and press down the lever (⑦), push your hips forward to slide the seat cushion to a proper position, then release the lever.

To reduce: When leaving or half up, press down the lever, and the seat cushion can return to the rear position or release the lever when it reaches the desired position.

Backrest angle adjustment (Tilt Lock):

To unlock: Turn the knob (⑧) backward.

To lock: Turn the knob forward when reaching desired angle.

Attention: Mechanism with safety lock, after unlock operation, the back will not return immediately, need to recline and then can be fully unlock.

Lumbar support adjustment:

To inflate (air bag) depth: Hold and press the pump (⑨) until it reaches your desired position.

To reduce: Press the button (⑩) on the pump to release the air until it reaches your desired position.

